

***MINIATURE LINEAR* Motor**

JSAH Series
JDAH Series
(Coreless Type)



Justek, Inc.

www.justek.com

MODEL : JTKL1506

A. PERFORMANCE DATA

| PERFORMANCES | UNIT | JTKL1506 |
|--------------------------|---------------|----------|
| Peak Force | N | 19 |
| Continuous Force | N | 5 |
| Continuous Current | A_{rms} | 0.5 |
| Peak Current | A_{rms} | 2 |
| Force Constant | N/A_{rms} | 9.4 |
| Motor Constant | $N/W^{1/2}$ | 2.1 |
| Electrical Time Constant | ms | 0.26 |
| Thermal Resistance | $^{\circ}C/W$ | 6.0 |
| Attraction Force | N | 0 |
| Moving Coil Mass | g | 70 |
| Magnet Track Mass | kg/m | 3.2 |

B. PERFORMANCE CURVE

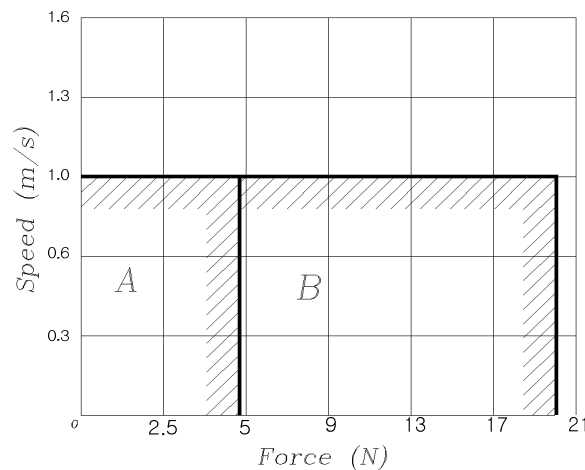

(A : Continuous Duty Zone , B : Intermittent Duty Zone)

Note : In case that supply input voltage of the JSMD servo driver is AC 220V.

Specifications are subject to change without notice.

C. Miniature Linear Motor Stage Specifications

- Single-axis Stage Spec.

| | UNIT | JSAH20 | JSAH40 | JSAH60 | JSAH80 | JSAH100 | JSAH125 |
|--|------------------|--------|--------|--------|--------|---------|---------|
| Normal Load Capacity | kg | 5 | 5 | 5 | 5 | 5 | 5 |
| Average Acceleration (Note2) | m/s ² | 2.5 | 2.5 | 2.5 | 2.5 | 2.5 | 2.5 |
| Maximum Velocity (Note2) | m/s | 0.2 | 0.3 | 0.35 | 0.4 | 0.5 | 0.55 |
| Straightness | um | 3 | 3 | 3 | 3 | 4 | 4 |
| Flatness | um | 6 | 6 | 8 | 8 | 10 | 10 |
| Positional Accuracy (Note3) | um | 3 | 3 | 4 | 4 | 5 | 5 |
| Bi-directional Repeatability (Note3) | ±um | 1 | 1 | 1 | 1 | 1 | 1 |
| Total Weight | kg | 1.8 | 2.0 | 2.2 | 2.4 | 2.6 | 2.8 |
| Mover Weight | kg | 0.7 | 0.8 | 1.0 | 1.1 | 1.3 | 1.4 |

NOTE

1) Measured at the mover center with no load(Temp. 20±2°c).

2) Encoder resolution : 1um

3) Encoder resolution : 0.1um

※ Acceleration, Velocity, Accuracy, Repeatability dependent upon encoder resolution

D. Miniature Linear Motor Stage Dimension

- Single-axis Stage Dimension

| JSAH-SERIES | STROKE(ST) | A | B | C | D |
|-------------|------------|------|-----|---|----|
| JSAH-20 | 20 | 0 | 5 | 2 | 10 |
| JSAH-40 | 40 | 15 | 15 | 2 | 5 |
| JSAH-60 | 60 | 25 | 25 | 2 | 5 |
| JSAH-80 | 80 | 35 | 10 | 3 | 5 |
| JSAH-100 | 100 | 45 | 20 | 3 | 5 |
| JSAH-125 | 125 | 57.5 | 7.5 | 4 | 5 |

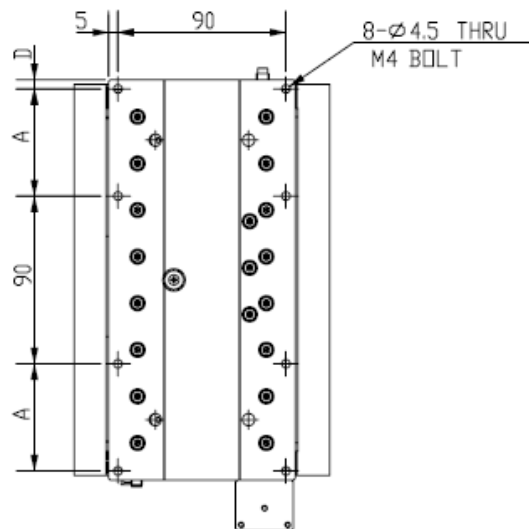
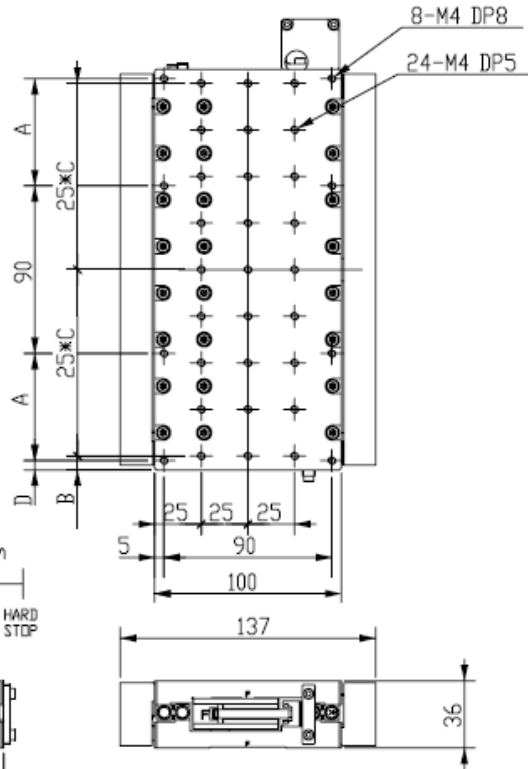
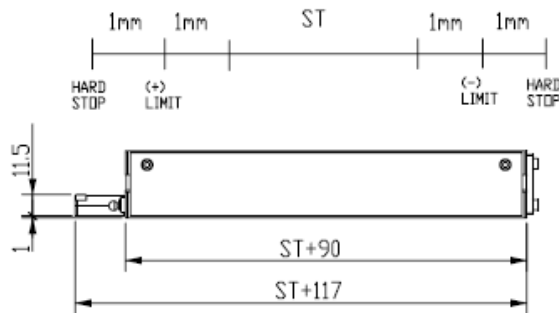

- Single-axis Stage : JSAH

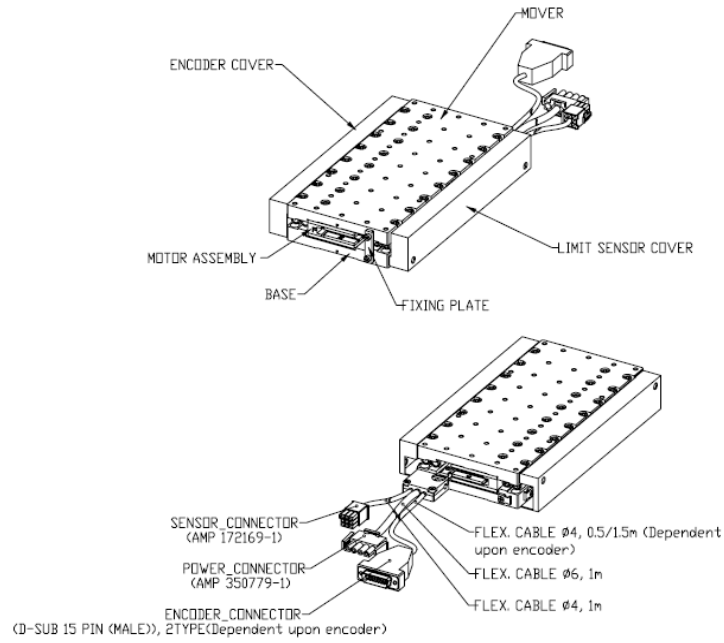

- Cross-axis Stage : JDAH

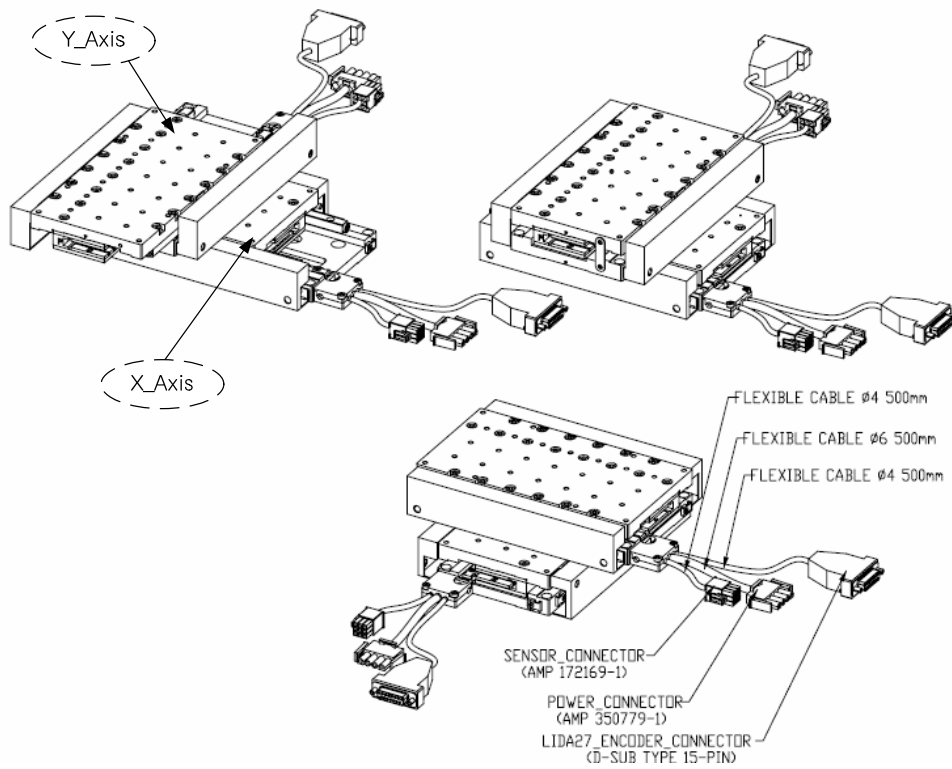

E. Miniature Linear Motor Stage Table

- Single-axis Stage Order Example :

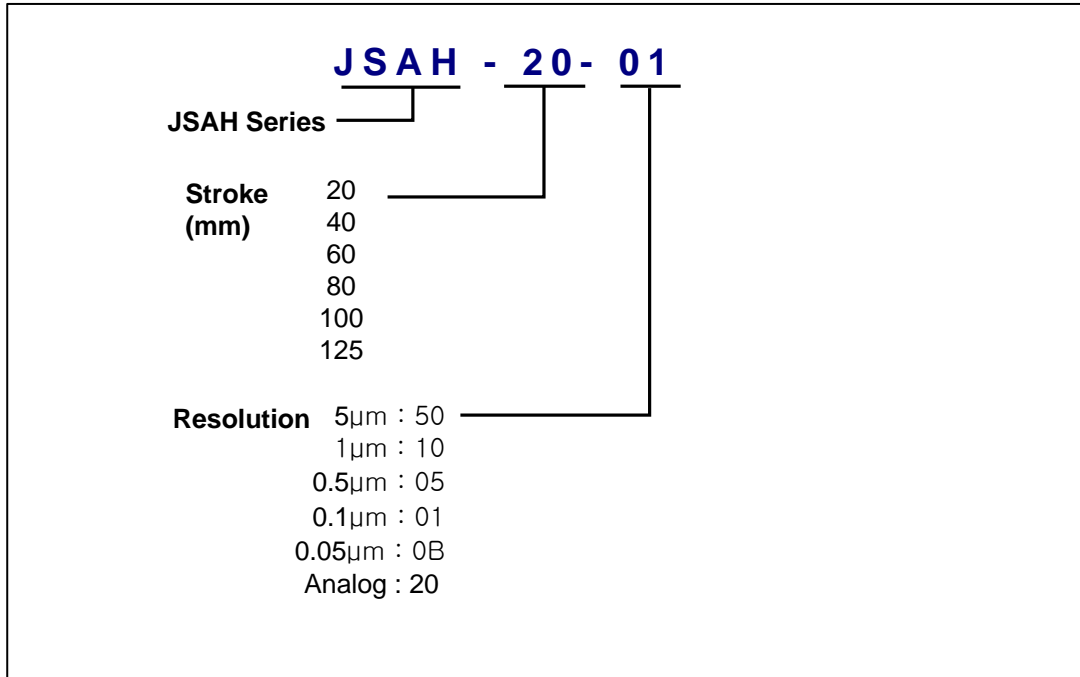

- Cross-axis Stage Order Example :

